

AICC Data Sheet

Version 2008-08-14

Goal

The development of a concept car which shall be able to locate defined indoor targets, avoiding obstacles and plan its way autonomously.



bio|s|wg

We decided to split our project into two main parts. Additionally we (re)used parts of a previous project.

Part 1

Build up a remote controlled car including the required sensors for autonomous driving – described with pictures on the following pages.

Part 2

Software part (expert system) – **work in progress.**

Part 1 – Power

The car has 8 motors in order to power and steer each of the four wheels separately.

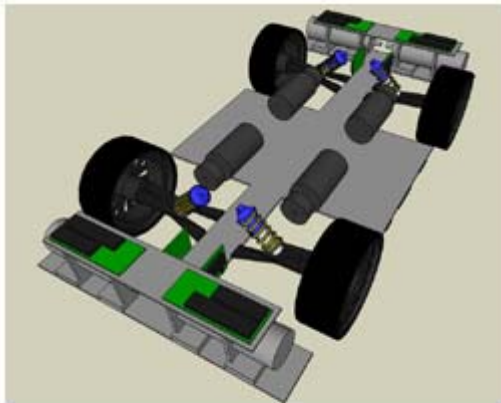

bio|s|wg

These 8 motors are controlled by 8 motion control units which are connected with an iso-k-line-bus-system.

For our specific application we developed a power supply which provides up to 500 watts constant load and 800 watts peak load. The power supply board (controlled by the mainboard) is able to switch each voltage separately. Additional features are a voltage, temperature and current monitoring interface.

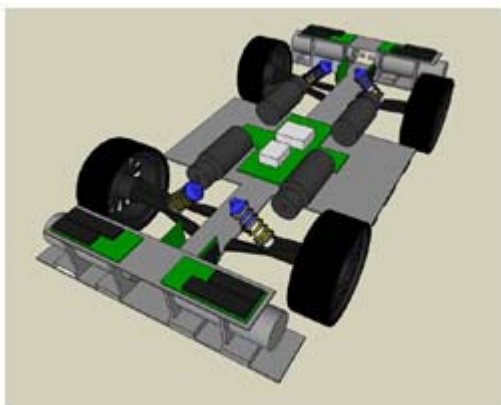

bio|s|wg

We use Lithium polymer accumulator technology. The advantages of this technology are the high peak load current, high power density and low weight. These accumulators require a complex charge control.

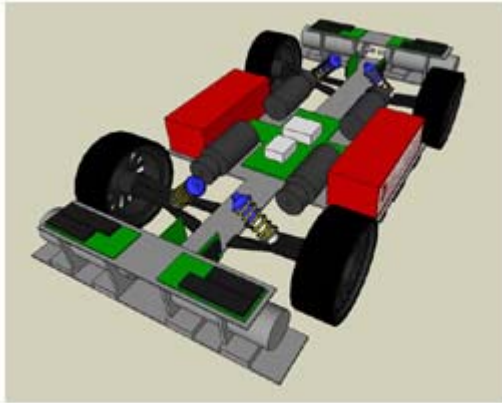

bio|s|wg

The accu packs in use provide low voltage cutoff and load balancing.

Part 1 – Mainboard & Sensors

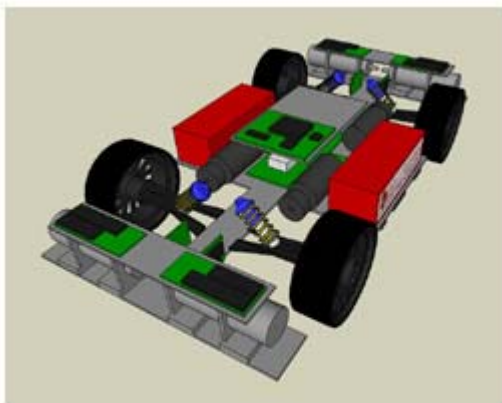

bio|s|wg

The mainboard controls all functions of the car. We use two pic micro controllers to do so.

It controls the power management, the temperature, voltage and current monitoring, the steering node configuration, the geometrically correct steering, the electrical differential as well as the steering and driving of each wheel.

It also evaluates the four incremental encoders which are part of the autonomous driving capability.

We use Ethernet to send driving instructions and to control the car via WLAN. Additionally we use USB for diagnostic purposes.

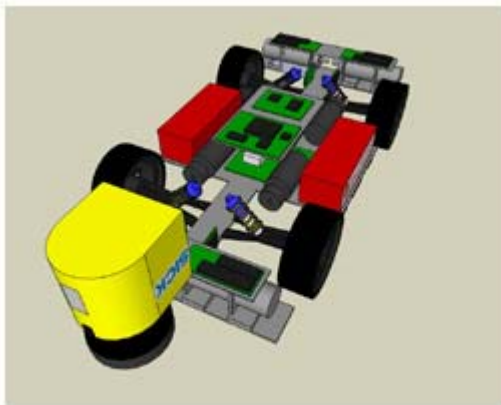

bio|s|wg

Two different sensor types are used:

A line laser scanner which is based on the principle of radar-systems. This technology is called LIDAR (Light Detecting and Ranging).

These sensors are lightweight, accurate real time capable and most suitable for our application.

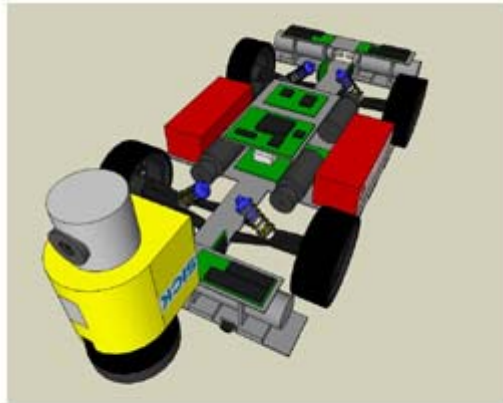

bio|s|wg

Additionally we use supersonic sensors to provide the detection of dangerous inclines and obstacles which are located underneath the car. Therefore a quick response emergency brake signal for the mainboard is provided as well as an evaluation of the supersonic sensor data and the switching outputs of the LIDAR sensor. The evaluated sensor data are reported via Ethernet.

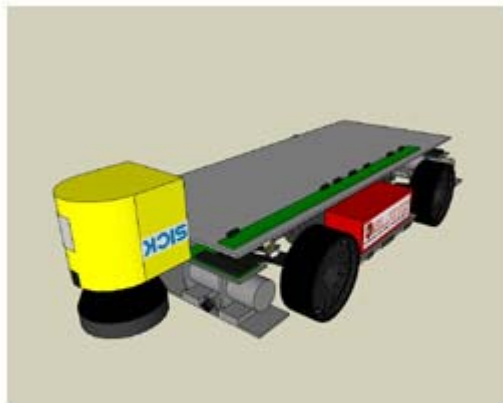

bio|s|wg

The power rail is part of the power supply and powers the embedded system, the LIDAR sensor and the WLAN equipment. It also enables the mainboard to switch these components on and off.

Part 1 – Remote Controlled Driving

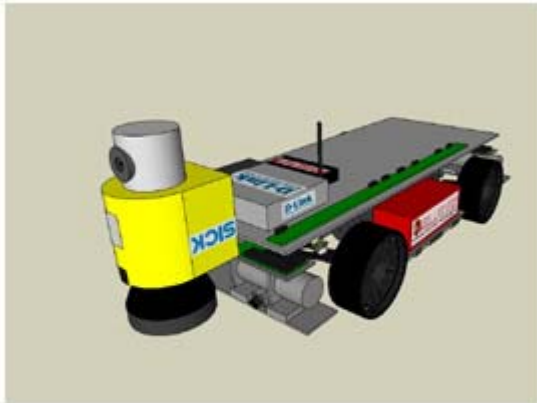

bio|s|wg

The WLAN-system provides the remote-control communication and sends the images of the webcam to the host PC.

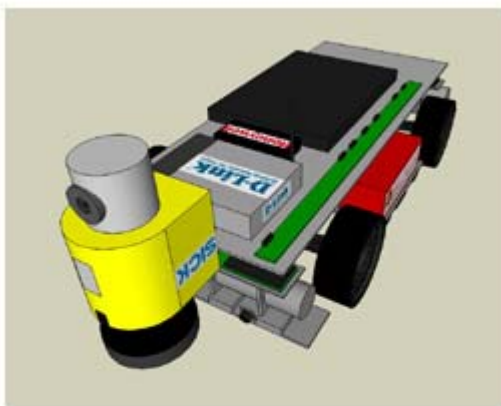

bio|s|wg

The embedded system is the brain of AICC. It's the platform of the navigation and the autonomous driving software (to be developed), which will send driving instructions to the mainboard. Probably we will use a laptop for that.